

SINGLE LIGHT DIAGRAM

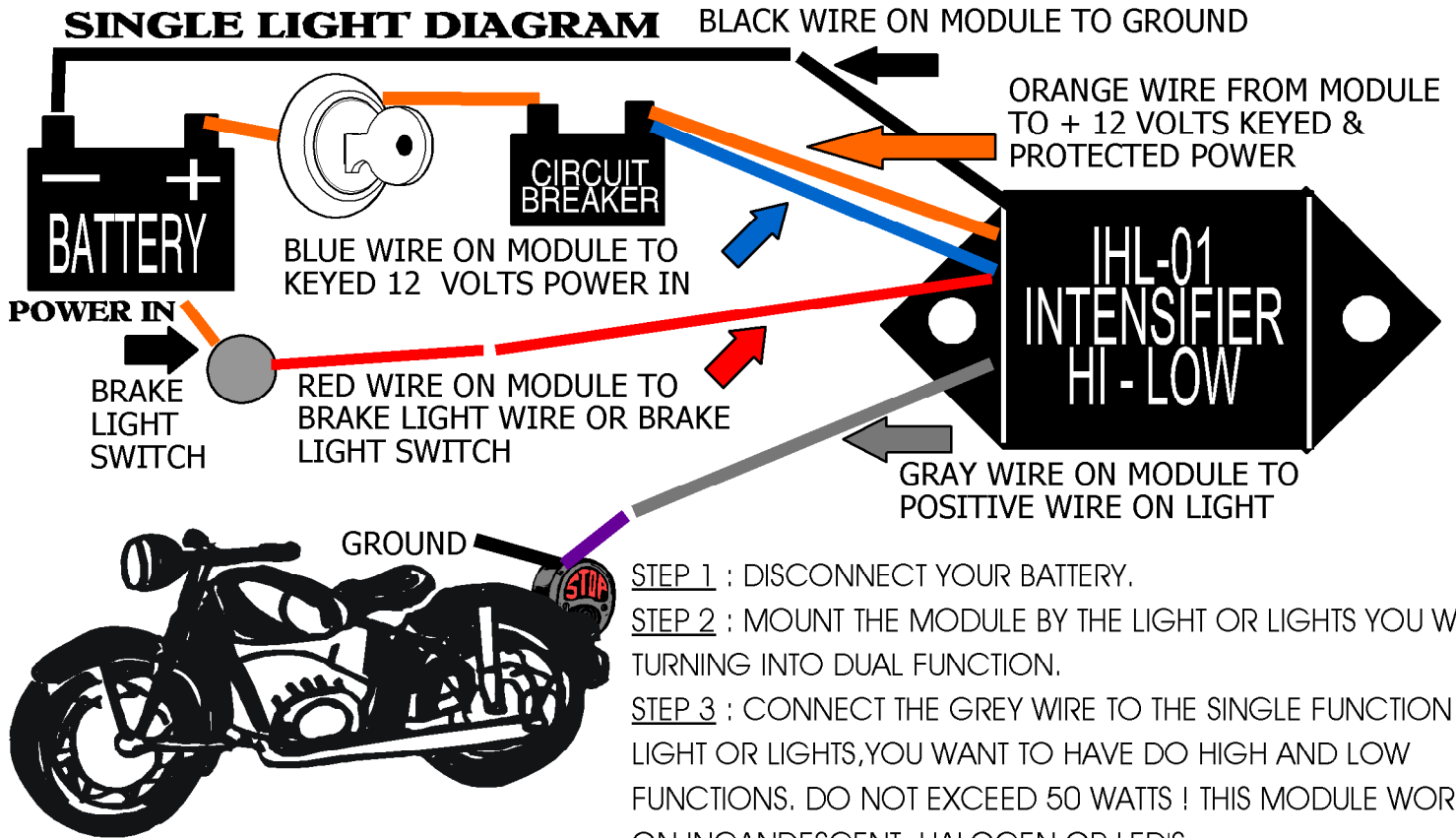

2 LIGHT DIAGRAM

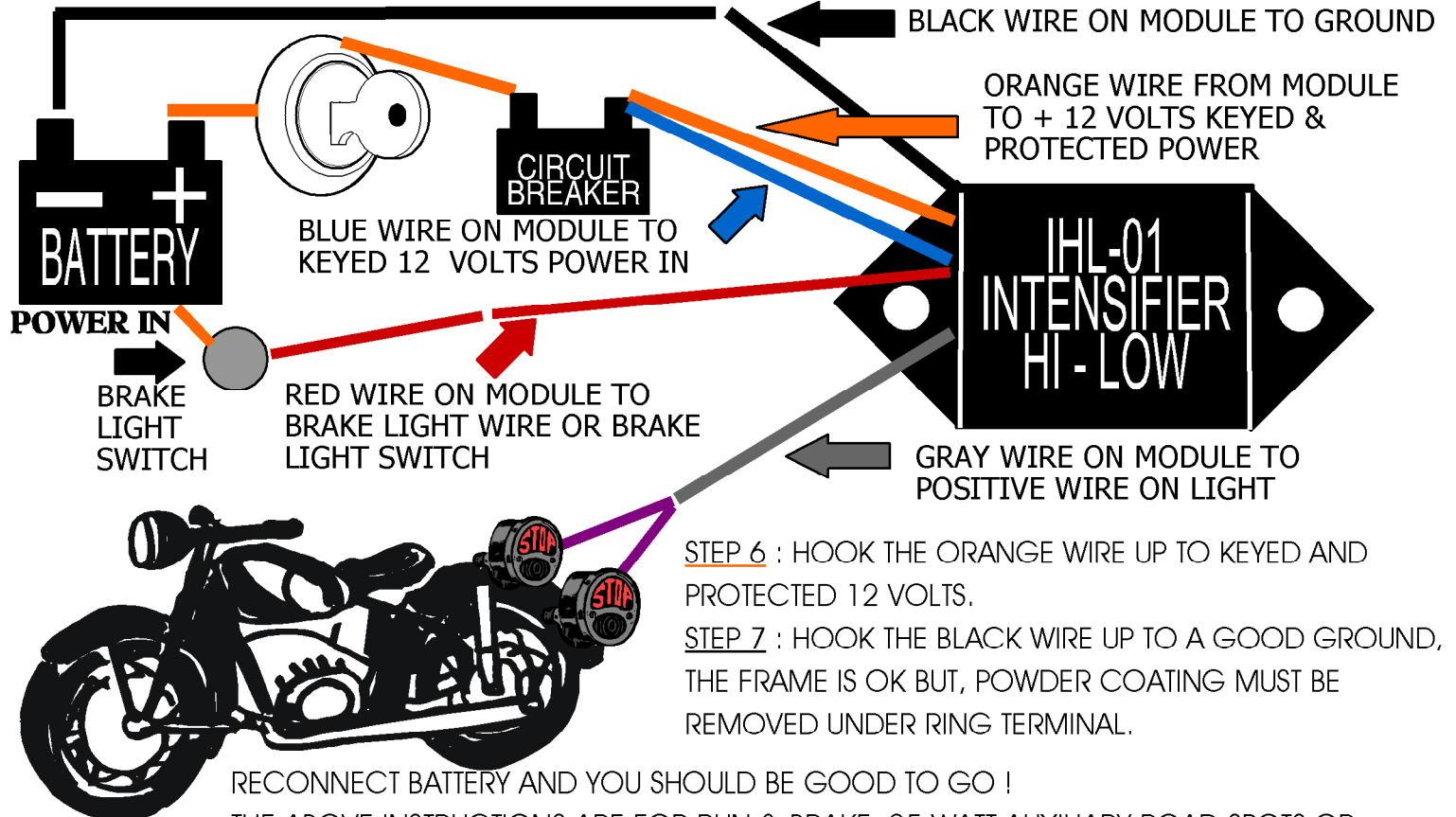

THE ABOVE INSTRUCTIONS ARE FOR RUN & BRAKE, 25 WATT AUXILIARY ROAD SPOTS OR NEON ACCENT LIGHTING. FOR FRONT OR REAR SIGNALS, TO DO RUNNING LIGHTS AND BLINKING, YOU WILL NEED 2 MODULES. THE WIRING WILL BE IDENTICAL, EXCEPT ON THE RED WIRE. THE RED WIRE WILL GO TO THE TURN SIGNAL OUTPUT WIRE, TO MAKE THE FRONT OR REAR LIGHTS FUNCTION AS RUN & TURN. .